

Mass spectrometry

Orbitrap Exploris 240 Mass Spectrometer

Leading performance

Introduction

The Thermo Scientific™ Orbitrap Exploris™ 240 mass spectrometer is a Thermo Scientific™ quadrupole-Orbitrap™ mass spectrometer, which is based on proven hardware and instrument control software designs of the next-generation Thermo Scientific mass spectrometers and incorporates extensive customer and service engineer feedback.¹

Built on the guiding principle of ease-of-use and reliable hardware, robust system performance boosts sample throughput. Soundness of data is assured with high-resolution accurate-mass (HRAM) selectivity, high scan speed and best-in-class mass spectral quality, all within a compact footprint to conserve bench space.

The Orbitrap Exploris 240 mass spectrometer provides the performance and versatility needed to drive discovery and identification, and the quantitative precision and accuracy to confidently scale up for impact. Operational simplicity with intelligent acquisition of high-resolution accurate-mass data (HRAM) provides the fast path to high-quality results for users of all skill levels in a range of applications including small molecule, peptide, and intact protein analyses.

Benefits

- Premium quantitative and qualitative performance with the fast-scanning High-Field Thermo Scientific™ Orbitrap™ mass analyzer
- Next-generation software with intuitive tuning, single-click calibration, drag-and-drop method setup, and pre-defined experiments
- Compatible with Thermo Scientific™ next generation ion sources including FAIMS Pro Duo interface
- Comprehensive, automated sample profiling with Thermo Scientific™ AcquireX™ data acquisition workflow



- Set up and forget with maximum mass accuracy provided, using built-in Thermo Scientific™ EASY-IC™ ion source internal reference mass
- Extended mass transmission and detection up to m/z 8,000 with the Thermo Scientific™ BioPharma option

Hardware features

Ion source

Thermo Scientific™ OptaMax™ NG ion source

- Ultimate sensitivity with an efficient, heated electrospray ionization (H-ESI) sprayer to deliver maximum performance with minimal optimization
- Additional non-heated low-flow calibrant sprayer for optimal mass and system calibration
- Flow rates from 1–1,000 $\mu\text{L}/\text{min}$:
 - low flow needle 1–10 $\mu\text{L}/\text{min}$
 - high flow needle 10–1,000 $\mu\text{L}/\text{min}$
- Enhanced ruggedness and reduced chemical noise with sweep gas

Ion optics

The atmospheric pressure ionization (API) interface consists of:

Round bore transfer tube

- Removable, heated ion transfer tube
- Vent-free maintenance

Stacked-ring ion guide (S-lens)

S-lens stacked-ring radio frequency (RF) ion guide captures and efficiently focuses the ions into a tight beam. Large variable spacing between electrodes allows for better pumping efficiency and improved ruggedness.

Advanced active beam guide (AABG)

- Reduces noise by preventing neutrals and high-velocity clusters from entering the quadrupole mass filter using a double bent design geometry
- Axial field along the length of the rods improves ion transfer robustness

Advanced quadrupole technology (AQT)

- Segmented quadrupole mass filter for precursor ion selection with variable precursor isolation width from 0.4 to 2,000 Da
- MS/MS precursor ion selection with high transmission from m/z 40 to 2,500

Ion-routing multipole (IRM)

- Robust ion trapping for MS scans and higher energy collisional dissociation (HCD)
- Nitrogen collision gas

Automatic gain control (AGC)

Reliable AGC measurements for controlled injection of the number of ions is ensured by the novel Independent Charge Detector

Thermo Scientific™ Orbitrap™ mass analyzer

- High-Field Orbitrap mass analyzer with 4 kV central electrode voltage
- Low noise detection pre-amplifier

Vacuum system

- A compact single six-stage turbomolecular pump design regulates the vacuum in six stages for the aluminum high-vacuum analyzer chambers
- Advanced vacuum technology reduces pressure in the ultra-high vacuum regions, enhancing transmission of ions to the Orbitrap mass analyzer

Thermo Scientific™ EASY-IC™ ion source

- Provides <1 ppm RMS mass accuracy under defined conditions with minimum effort for at least five days
- Generates optional internal reference ions for real-time mass correction of spectra in both positive and negative ionization mode

Optional hardware

BioPharma option

- Analysis of large molecules including intact proteins and large complexes sprayed under denatured or native conditions
- Includes mass transmission and detection up to m/z 8,000

Thermo Scientific™ EASY-Spray™ NG ion source

- Maximum nanoelectrospray performance with minimum adjustment

Thermo Scientific™ Nanospray Flex™ NG ion source

- Supports static and dynamic electrospray experiments
- Compatible with liquid flow rates of 50–2,000 nL/min

APCI/APPI probe for OptaMax NG ion source

- Compatible with flow rates from 50–1,000 $\mu\text{L}/\text{min}$ without splitting
- The APCI probe can be upgraded to APPI

Thermo Scientific FAIMS Pro Duo interface

- FAIMS Pro Duo interface (high field asymmetric ion mobility spectrometry) augments analytical selectivity, enabling identification and quantitation of more proteins while reducing time-consuming sample preparation
- Performs online gas-phase fractionation based on differential ion mobility
- Optimized for 0.1–1,000 $\mu\text{L}/\text{min}$ flow rates
- CV switching time of 40 ms

Orbitrap Exploris 240 mass spectrometer ion path

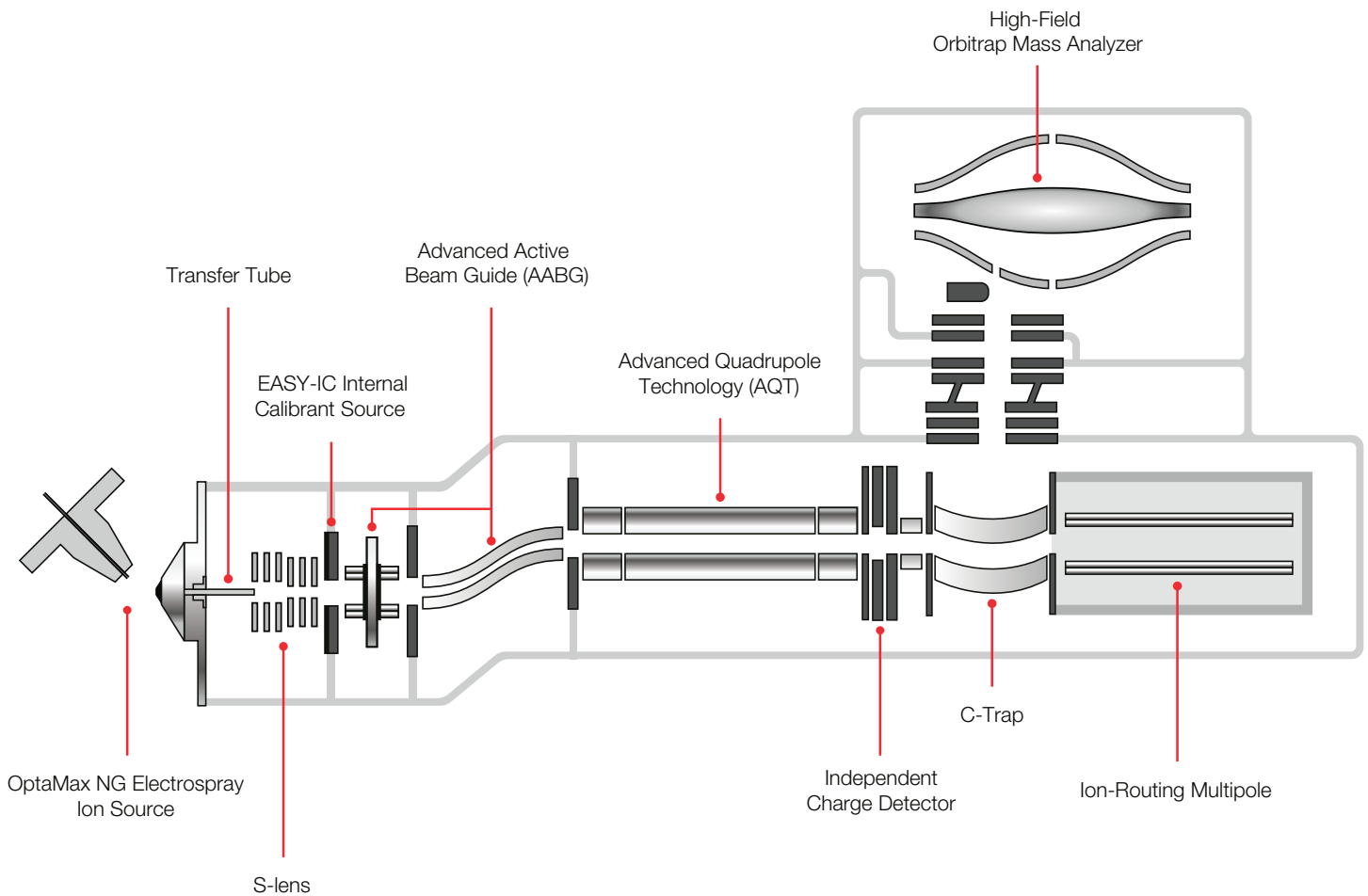

Performance specifications

Mass range	Standard mass range m/z 40–6,000, up to m/z 8,000 with BioPharma option
Orbitrap mass analyzer resolution	Up to 240,000 at m/z 200
Scan rate*	Up to 30 Hz at resolution setting at 11,250
Mass accuracy*	External calibration achieves <3 ppm RMS drift over 24 hours; 1-point calibration achieves <3 ppm RMS drift over at least 4 weeks; Internal lock mass calibration achieves <1 ppm RMS drift over 24 hours; EASY-IC achieves <1 ppm RMS drift for at least 5 days
Instrument detection limit	Full Scan: < 3.0 fg reserpine on column tMS2: < 3.0 fg reserpine on column tSIM: < 1.5 fg reserpine on column
Sensitivity	MS/MS: 200 fg reserpine on column S/N 100:1 tSIM: 200 fg reserpine on column S/N 250:1
Dynamic range*	>5,000 within a single Orbitrap mass analyzer spectrum
Polarity switching	One Full Scan cycle** <700 ms equals >1.4 Hz One tSIM Scan cycle** <600 ms equals >1.6 Hz
Multiplexing	Up to 20 precursor ions per scan
Analog inputs	Channel 1 analog input (± 10 V), Channel 2 analog input (± 10 V)

* Under defined conditions

** One cycle consists of acquiring one Full Scan in positive mode and one Full Scan in negative mode at resolution setting 60,000
one tSIM Scan in positive mode and one tSIM Scan in negative mode at resolution setting 60,000

Data acquisition system

Data System

- High-performance PC with Intel® microprocessor
- High-resolution LED color monitor
- Microsoft® Windows® 10 Enterprise (Long Term Service version) operating system
- High-speed real-time data acquisition and instrument control
- Automatic calibration of all ion transfer and analysis parameters via instrument control software

Thermo Scientific™ Orbitrap Exploris™ instrument control software

- Tune application for instrument mass and system calibrations and checks, diagnostics, and manual data acquisition
- Method Editor with a comprehensive application-specific template library, method setup supported by tooltips, and a drag-and-drop user interface to facilitate method development
- Consistent instrument control software whether using Xcalibur software, Thermo Scientific™ Chromeleon™ Chromatography Data Systems (CDS) or Thermo Scientific™ TraceFinder™ for data acquisition

Thermo Scientific™ Xcalibur™ software

- Xcalibur software is the acquisition software for the next-generation Thermo Scientific mass spectrometer portfolio
- Accelerates familiarization and reduces training needs

Thermo Scientific AcquireX Intelligent Data Acquisition Workflow

AcquireX data acquisition workflows provide comprehensive small molecule sample profiling on an LC timescale using automated, logic-based sample re-injection with inter-run inclusion and exclusion lists

Operation modes

Resolution settings

Ranging from 11,250 to 240,000 at m/z 200

Application-specific system templates

- Sets optimal default instrument parameters and manages application-specific system templates for easy method development and execution.

Application Modes

Sets optimal default instrument parameters and manages application-specific system templates for easy method development and execution. Available modes are:

- Small molecule
- Peptide
- Intact Protein (included with BioPharma option)

Advanced Peak Determination (APD)

Precursor annotation algorithm for improved charge state assignment to increase the number of precursors available for data-dependent analysis

General

- Application Modes 'Small Molecule', 'Peptide', 'Intact Protein' are available
- With Application Mode 'Small Molecules', a method can apply to Xcalibur AcquireX workflows (optional); it is a global setting and applies to the entire run
- 'Mild Trapping' is available with Application Mode 'Small Molecule' and can be applied optionally for particularly labile compounds; it is a global setting and applies to the entire run
- With Application Mode 'Intact Protein', pressure regimes (low, standard and high) can be selected for best performance with native and denaturing conditions
- APD is available optionally with all Application Modes. APD can be checked for improved determination of a) charge states and b) monoisotopic m/z values of isotopic envelopes
- Multiple experiments can be set up within one method
- One experiment can contain combinations of scans
- 'Collision Energy Type' can be selected: 'Normalized (NCE)' and 'Absolute (CE)'
- 'Collision Energy Mode' can be selected: 'Fixed' and 'Stepped'

Scan functions

Unique scan types are available

- Full MS scan
- AIF
- tSIM
- DIA
- tMS²

and combinable within a single experiment, such as:

- Full Scan ddMS²
- Full Scan ddSIM

Both with 'Number of Scans' (= TopN) or 'Cycle Time'

In addition, multiple experiments can be created combining all of the above listed scan types.

Filters

Filters guide data-dependent (discovery and confirmational) decisions on the fly and in real time. To achieve optimum results when applying application- and sample-dependent filter settings, the user is guided with appropriate application-dependent parameter settings and tool tips with tailored recommendations and detailed 'learn more' sections.

Filters can be selected as follows:

- Dynamic Exclusion
- Intensity
- Precursor Fit
- Charge State
- Targeted Inclusion
- Targeted Exclusion
- MIPS (Monoisotopic Precursor Selection)
- Apex Detection
- Isotope Exclusion

Optional data acquisition and analysis software

Thermo Scientific™ Proteome Discoverer™ software

Simplifies a wide range of proteomics workflows, from protein and peptide identification to PTM analysis to isobaric mass tagging, and SILAC and label-free quantitation

Thermo Scientific™ BioPharma Finder™ software

Provides complete protein characterization, including intact protein mass analysis, top- and middle-down analysis, peptide mapping or multi-attribute method (MAM) workflows

Thermo Scientific™ ProSightPD™ software

Stand-alone software for analyzing top-down, middle-down, and bottom-up data

Thermo Scientific™ Compound Discoverer™ software

Streamlines small molecule unknown identification, determination of real differences between samples, and elucidation of biological pathways with an integrated suite of data analysis tools

Thermo Scientific™ TraceFinder™ software

Acquire and process your high-throughput screening and quantitation with built-in intelligence, driving productivity gains from data acquisition and processing to reporting.

Thermo Scientific™ Chromeleon™ Chromatography Data System (CDS)

Streamlined chromatographic and MS screening and quantitative workflows within an enterprise and compliance-ready single software application

Installation requirements

Power

- 2×208–240 Vac single phase, 15 A, 50/60 Hz, with earth ground for instrument and source vacuum pump
- 208–240 Vac single phase, 15 A, 50/60 Hz, with earth ground for the data system

Gas

- Source gas: high-purity nitrogen gas supply (>99% pure at 600 ± 50 kPa [6.0 ± 0.5 bar, 87 ± 7 psi])
- A pre-regulator might be required to keep the source gas pressure stable within the required limits
- HCD collision gas: ultra-high-purity nitrogen (UHP > 99.999% pure†) at 600 ± 50 kPa [6.0 ± 0.5 bar]
- With EASY-IC: ultra-high-purity nitrogen (UHP > 99.999% pure†) at 600 ± 50 kPa [6.0 ± 0.5 bar]

† with less than one ppm each water and oxygen

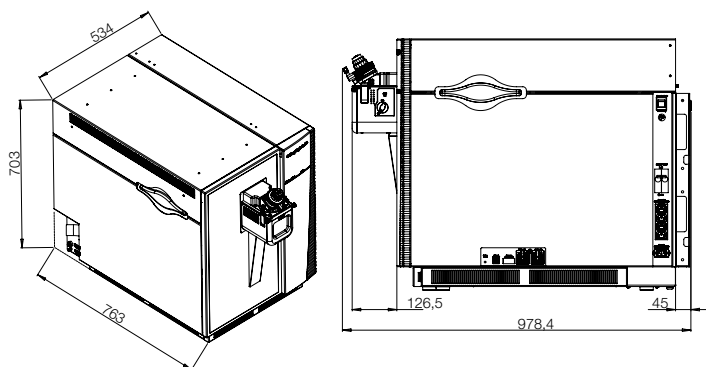

Dimensions (w, d, h)

- 534 × 763 × 703 mm (21 × 30 × 27.7 in)

Weight

- 120 kg (265 lb) without data system, vacuum rough pumps, and optional items

Environment

- System averages 3440 W (11,730 Btu/h) output when considering air conditioning needs
- Operating environment must be 18–27 °C (64–81 °F). Relative humidity must be 20–80% with no condensation
- Designed for indoor use at an altitude of up to 3,000 m (10,000 ft) above sea level

Reference

1. Thermo Scientific™ Orbitrap™ Tribrid™ mass spectrometers, Thermo Scientific™ TSQ Altis™ triple quadrupole mass spectrometer, Thermo Scientific™ TSQ Quantis™ triple quadrupole mass spectrometer, Thermo Scientific™ TSQ Fortis™ triple quadrupole mass spectrometer, and Thermo Scientific™ Orbitrap Exploris™ mass spectrometers

Learn more at thermofisher.com/OrbitrapExploris240